

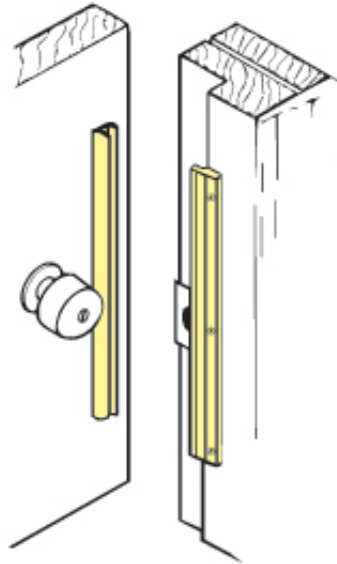

In-Swinging Latch Protector ILP 206



Product Specifications

Number	ILP 206
Dimensions	6"
Gauge	14 ga., .075
Material	Steel
Shelf pack	10
Features	For use with key-in-knob and deadbolt locks, For in-swinging doors
Finishes	BP, CP, DU, SL
Competitor part	8840, ELP-100

